

SUPPER JOPIX

10 METER BAND
AMATEUR BASE TRANSCEIVER

Model
SJ-3000B

OWNER'S MANUAL

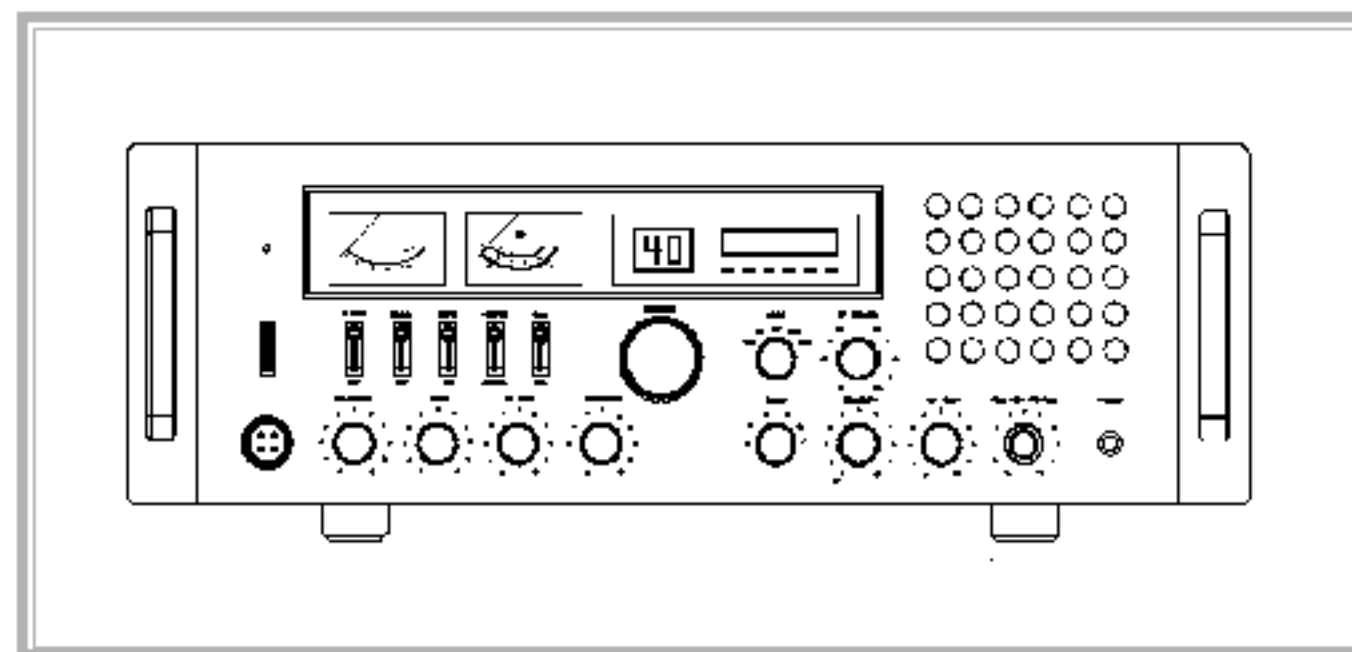

If you Think you Need Service Contact JOPIX Radio Dealer

You may be asked to send your unit to our dealer. It will be necessary to furnish the following, in order to have the product serviced and return.

1. For Warranty Repair included some form of proof-of-purchase, such as a mechanical reproduction or carbon or a sales receipt. If you send the original receipt it cannot be returned.
2. Send the entire product.
3. Enclose a description of what is happening with the unit, include a typed or clearly printed name and address of where the unit is to be returned.
4. Pack unit securely to prevent damage in transit. If possible, use the original packing material.
5. Ship prepaid and insured by way of a traceable carrier, such as United Parcel Service (UPS), Roadway Parcel Service (RPS) or the First Class Mail to avoid loss in transit to dealer or the factory.
6. If you received the radio product as a gift and you do not have the proof-of-purchase information necessary for service, include the following information with the product.

Clearly printed or typed name and address. Date, Month and Year of you received the gift. Model number. Where purchased (if Possible) store name and location.

TABLE OF CONTENTS

	PAGE
INTRODUCTION	1
SPECIFICATIONS	
General	2
Transmitter & Receiver	3
INSTALLATION	
Location of the Radio / Base Antenna	4
Tuning the Antenna for Optimum SWR	5
Tips for antenna adjustment / Extend Speaker	6
OPERATION	
Location of Controls Front Panel	7
Location of Controls Rear Panel	8
Control functions Front Panel	9~11
Control functions Front/Rear Panel (continuation)	12
Control functions Rear Panel (continuation)	13
PTT Microphone / Operating Procedure to Rx & Tx	14
Receiving SSB Signals/Roger Beep	15
Alternate Microphones schematic	16
Alternate Microphones and Installation / Mic. Plug Reassembling	17
Mic. Plug Reassembling	18
IMPORTANT SAFEGUARDS	
Caution Risk of Electric Shock	19
Safety Instructions	20~23
SERVICE INFORMATION	
Warranty and Service	24
Service	Rear

SPECIFICATIONS

MODEL: SJ-3000B BASE STATION

GENERAL

Frequency Range		28.315 to 28.766 MHz.
Frequency Control		Phase Lock Loop (PLL) synthesizer.
Frequency Tolerance		0.005%
Frequency Stability		0.001%
Operating Temperature Range		-30°C to +50°C.
Microphone		Plug-in dynamic; with push-to-talk switch and coiled cord.
Input Voltage	A.C. D.C.	110~120V or 220~240V 50/60Hz selectable. 13.8V Regulated.
DC Current Drain	Tx Rx	AM 10W with full mod / 4A. FM 10W / 3.5A SSB 21 Watts PEP / 6A Squelched / 0.6A. Maximum AF output / 1.2A
Size		6-3/8"(H) x 19"(W) x 13"(D)
Weight		18.5 lbs.
Antenna Connector		UHF, SO239.
Meter Illuminates	Rx Tx	Indicates received signal strength. Indicates RF power output & SWR.

IMPORTANT SAFEGUARDS

Continuation

SAFETY INSTRUCTIONS

- 21 REPLACEMENT PARTS :**
When replacement parts are required, be sure the service technician had used replacement parts specified by the manufacturer that have these same characteristics as the original part. Unauthorized substitutions may result in fire, electric shock, injury to persons or other hazards.
- 22 SAFETY CHECK :**
Upon completion of any service or repairs to the NS-9500, ask the service technician to perform routine safety checks to determine that the transceiver is in proper operating condition.

IMPORTANT SAFEGUARDS

Continuation

SAFETY INSTRUCTIONS

- 14 LIGHTNING :**
For added protection the receiver during a lightning storm, or when it is left unattended and unused for long periods of time, unplug it from the wall outlet and disconnect the antenna or cable system. This will prevent damage to the transceiver due to lightning and power-line surges.
- 15 POWER LINES :**
An outside antenna system should not be located in a vicinity of overhead power lines or other electric light or power circuit, or where it can fall into such power lines or circuits as contact when they might be fatal.
- 16 OVERLOADING :**
Do not overload wall outlet and extension cords as this can result in a risk of fire or electric shock.
- 17 OBJECT AND LIQUID ENTRY :**
Never push objects of any kind into this transceiver through opening as they may touch dangerous voltage points or short out parts that could result in fire or electric shock. Never spill liquid of any kind on the transceiver.
- 18 HEAT :**
The appliance should be situated away from the heat source such as radiators, heat registers stoves, or other appliances (including amplifiers) that produce heat.
- 19 NON-USE PERIODS :**
The power cord should be unplugged from the outlet when left unused for a long period of time.
- 20 DAMAGE REQUIRING SERVICE :**
Unplug the NS-9500 from the wall outlet and refer servicing to qualified service personnel under the following conditions:
- A. When the power-supply cord or the plug is damaged or frayed.
 - B. If the liquid has been spilled, or objects have fallen into the transceiver.
 - C. If the transceiver has been exposed to rain or water.
 - D. If the transceiver does not operate normally by following the operating instructions as improper adjustment of other controls may result in damage and will often require extensive work by qualified technician to restore the transceiver to its normal operation.
 - E. If the transceiver has been dropped or has been damaged.
 - F. When the transceiver exhibits a distinct change in performance this indicates a need of service.

SPECIFICATIONS

MODEL : SJ-3000B BASE STATION

TRANSMITTER

Power Output	AM / FM / CW = 10 W. SSB = 30W pep.
Modulation	AM = Hi / Lo level Class B. FM = Variable capacitance.
Intermodulation Distortion	SSB : 3rd order, more than -25 db 5th order, more than -35 db
SSB Carrier Suppression	55 db
Unwanted SideBand	50 db
Spurious Emissions	60 db
AF modulation response	AM / FM = 450 ~ 2500 Hz.
Output Impedance	50 Ω
Output Indicator	S Meter Tx Meter Tx LED
	Signal strength F.S. +30db AM=10W / SSB=30W pep full scale / SWR 1:1~ α set. Transmitting glows red

RECEIVER

Sensitivity	SSB AM FM	0.25 μ V for 10db (S+N)/N 0.50 μ V for 10db (S+N)/N 1.0 μ V for 20db (S+N)/N At greater than 0.5W AF output
Selectivity	AM/FM SSB	6db @ 3.0Khz 50db @ 9Khz. 6db @ 2.1Khz 60db @ 3.3Khz.
Image Rejection		More than 65 db
IF Frequency	AM / FM	1st= 10.695 Mhz. 2nd=455 Khz
Adjacent Channel	AM / FM	60 db & SSB 70db.
RF Gain Control		45db adjustable for optimum signal reception
Automatic Gain Control (AGC)		Less than 10db change in AF out for inputs 10 μ V~100mV
Squelch		Adjustable, threshold less than 0.5 μ V.
ANL		Switchable.
Noise Blanker (NB)		RF type effective on AM/FM and SSB.
Clarifier Range		Coarse: \pm 5Khz, Fine: \pm 1Khz. (Tx / Rx)
Audio Power		4 Watts into 8 ohms.
Frequency Response		300 ~ 2800 Hz.
Built-in Speaker		8 Ω 4W Round
External Speaker	Option	8 Ω disables internal speaker when connected

INSTALLATION

LOCATION OF THE RADIO

Prior to beginning operation of the transceiver, a basic installation must be prepared. Installation of the transceiver itself is a rather simple procedure.

In selecting the location for the unit, two basic factors must be considered:

- A. Access to a 120V, 60Hz power source.
- B. The location must be convenient for running the antenna lead-in cable if an outside antenna installation is proposed.

BASE STATION ANTENNA

Only a properly matched antenna system will allow maximum power transfer from the 50 ohm transmission line to the radiating element.

The recommended method of antenna tuning is to use the built-in SWR meter to adjust the antenna tuning for minimum reflected power on channel 20.

The radio may be used with any type of 50 ohm base station antenna. A ground plane vertical antenna will provide the most uniform horizontal coverage. This type of antenna is best suited for communication with a mobile unit. For point-to-point operation where both base stations are fixed, a directional beam will usually increase communicating range since this type of antenna concentrates transmitted energy in one direction. The beam antenna also allows the receiver to "listen" in only one direction, thus reducing interfering signals.

Antenna height is an important factor when maximum range is desired. Keep the antenna clear of surrounding structures or foliage. FCC regulations for base station antenna height are:

1. Omni-directional antennas may not be higher than 60 feet above the ground when using a tower, mast or pole, and no higher than 20 feet above an existing structure.

These are only general regulations applicable to most but not all parts of the nation. Locations near airports and some military installations are subject to different rules, therefore, it is best to contact your nearest Federal Communications Commission office for information regarding your specific area.

IMPORTANT SAFEGUARDS

Continuation

SAFETY INSTRUCTIONS

- 11 GROUNDING OR POLARIZATION :**
This transceiver product is equipped with a polarized alternating current line plug, a plug having one blade wider than the other. If you are unable to insert the polarized plug into the outlet, in the case of the polarized plug, try reversing the plug. If it should still fail to fit, contact an electrician to replace your absolute outlet.
- 12 POWER-CORD PROTECTION :**
Power-supply cords should be routed so that they are not likely to be walked on or pinched by items placed upon or against them, paying particular attention to cords at plugs, convenience receptacles, and the point where they exit from the appliance.
- 13 OUTDOOR ANTENNA GROUNDING :**
If an outside antenna is connected to the transceiver, be sure the antenna system is grounded so as to provide some protection against voltage surges and built up static charges. Article 810 of National Electrical Code, ANSI / NEPA No. 70, provides information with respect to proper grounding of the mast and supporting structure, grounding of the lead-in wire to an antenna - discharge unit, connection to grounding electrodes, and requirements for the grounding electrode.

See Figure A.

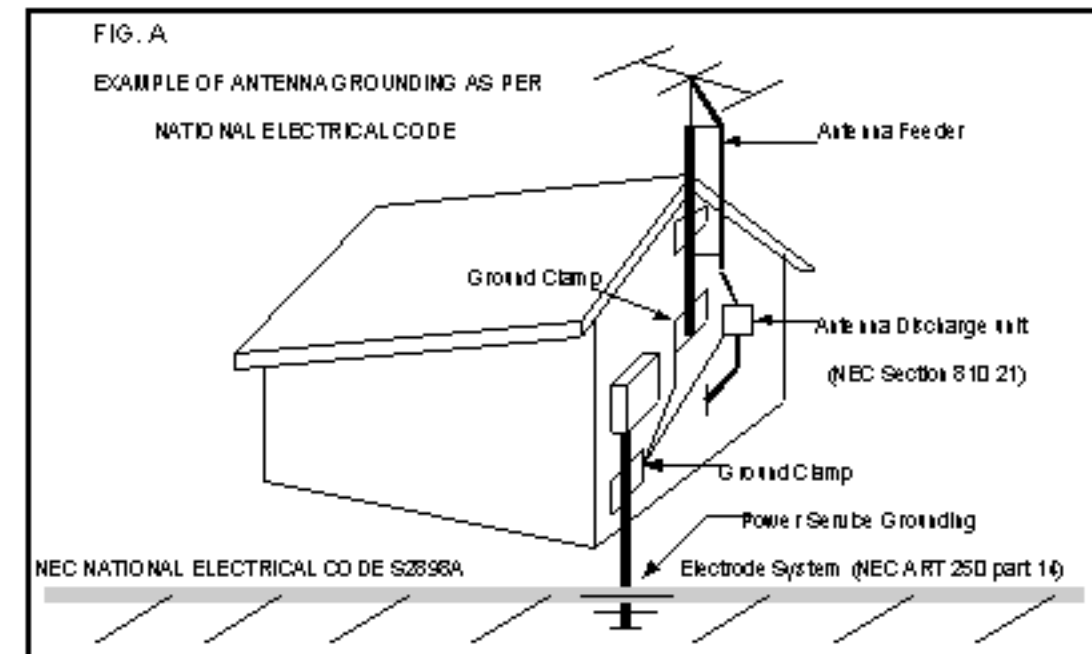

SAFETY INSTRUCTIONS

- ① **READ INSTRUCTIONS :**
All the safety and operating instructions should be read before the appliance is operated.
- ② **RETAIN INSTRUCTIONS :**
The safety and operating instructions should be retained for future reference.
- ③ **HEED WARNINGS :**
All warnings on the appliance and in the operating instructions should be adhered to.
- ④ **FOLLOW INSTRUCTIONS :**
All operating and use instructions should be followed
- ⑤ **CLEANING :**
Unplug this transceiver from the wall outlet before clearing. Do not use liquid cleaners or aerosol cleaners. Use a damp cloth for clearing.
- ⑥ **ATTACHMENTS :**
Do not use attachments not recommended by JOFIX as they may cause hazards.
- ⑦ **WATER & MOISTURE :**
Do not use this transceiver near water for example, near a bath tub, wash towel, kitchen sink, laundry tub, in a wet basement, or near a swimming pool.
- ⑧ **ACCESSORIES :**
Do not place the NS-9500 on an unstable cart, stand, bracket, or table. The transceiver may fall, causing serious injury to a child or adult, and serious damage to the appliance. An appliance and cart combination should be moved with care. Quick stops, excessive force, and uneven surfaces may cause the appliance and cart combination to overturn.
- ⑨ **VENTILATION :**
Slots and openings in the cabinet are provided for ventilation and to insure reliable operation of the transceiver and to protect it from over heating. These never openings must not be blocked or covered. The openings should never be blocked by placing the transceiver on a bed, sofa, rug, or other similar surface. This transceiver should never be placed near or over a radiator or heat register. This transceiver should not be placed in a built-in installation, such as a bookcase or rack unless proper ventilation is provided or the manufacturer's instructions have been adhered to.
- ⑩ **POWER SOURCE :**
Connect the SJ-3000B only to a 120-Volt, 60Hz AC power source.

TUNING THE ANTENNA FOR OPTIMUM SWR

BECAUSE the antenna length is directly related to the channel frequency, it must be tuned to resonate optimally all 40 channels of the transceiver. Ch.1 requires a longer antenna than Ch. 40, because it is lower in frequency.

DUE TO the various methods of adjusting antennas for proper SWR we have chosen what we think is the optimum method:

WARNING !
CONTINUOUS OPERATION OF THIS TRANSMITTER WITH GREATER THAN 4:1 VSWR ANTENNA MISMATCH MAY RESULT IN RF AMPLIFIER DAMAGE.

A. Antenna with adjustment screws (set screws)

1. Start with the antenna extended and tighten the set screw tightly enough so that the antenna can be lightly tapped with your finger for easy adjustment.
2. Set your transceiver to Ch. 20. Press PTT (push-to-talk) switch, and tap the antenna shorter.

The SWR meter will show a lower reading each time the antenna is tapped. By continuing to shorten the antenna you will notice the SWR reading will reach a lowest point and then start to rise again, this means the optimum tuning being pressed for center operating frequency of your transceiver.

B. Antennas which must be cut to proper length

1. Follow the same procedure as above, but adjust the length by cutting in 1/8 inch increments until a good match is obtained.
2. Be very careful not to cut too much at one time, as once it is cut, it can no longer be lengthened.
3. The whip is easily cut by filing a notch all the way around and breaking the piece off with pliers.



TIPS FOR ANTENNA ADJUSTMENT

IF YOU ARE HAVING DIFFICULTIES IN ADJUSTING ANTENNA CHECK THE FOLLOWING.

- A. All metal articles must not be closed when adjusting the antenna.
- B. Make sure the antenna base is grounded
- C. Check your coaxial cable routing to make sure it is not pinched when routed into the house.
- D. Is the antenna perfectly vertical ?
- E. Try a different location in your neighborhood. Stay away from large metal objects when adjusting, such as metal telephone or light poles, and fences, etc.

EXTERNAL SPEAKER IMPORTANT NOTE



The external speaker jack " **EXT. SPK.** " on the rear panel, is used for remote receiver monitoring. The external speaker should have 8 ohms impedance and be able to handle at least 4 watts. When the external speaker is plugged in, the internal speaker is disconnected.

 **IT HAS NO AUDIO OUTPUT FROM THIS JACK, WHILE SELECTED TO P.A. MODE OPERATION.**

IMPORTANT SAFEGUARDS

CAUTION RISK OF ELECTRIC SHOCK



WARNING!

To reduce the risk of fire or electric shock, do not expose this appliance to rain or moisture.

CAUTION RISK OF ELECTRIC SHOCK DO NOT OPEN

CAUTION: TO REDUCE THE RISK OF ELECTRIC SHOCK, DO NOT REMOVE COVER (OR BACK). NO USER SERVICEABLE PARTS INSIDE. REFER SERVICING TO QUALIFIED SERVICE PERSONNEL.



The lightning flash with arrowhead symbol within an equilateral triangle is intended to alert the user to the presence of un-insulated " DANGEROUS VOLTAGE " within the product's enclosure that may be of sufficient magnitude to constitute a risk of electric shock of persons.



The exclamation point within an equilateral triangle is intended to alert the user to the presence of important and operating and maintenance (servicing) instructions in the literature accompanying the appliance.

MICROPHONE PLUG REASSEMBLING

Be sure that the housing and the knurled ring of FIG. 3 are pushed back onto the microphone cable before starting to solder. If the washer is not captive to the pin receptacle body, make sure that it is placed on the threaded portion of the pin receptacle body before soldering.

If the microphone jack is used to hold the pin receptacle during the soldering operation, best results are obtained when the connections to pins 1 and 3 are made first and then the connections to pins 2, 4 and 5. Use a minimum amount of solder and be careful to prevent excessive solder accumulation on pins, which could cause a short between the pin and the microphone plug housing.

- ⑥ When all soldering connections to the pins of the microphone plug are complete, push the knurled ring and the housing forward and screw the housing onto the threaded portion of the pin receptacle body. Note the location of the screw clearance hole in the plug housing with respect to the threaded hole in the pin receptacle body. When the housing is completely threaded into the pin receptacle body, a final fraction of a turn either clockwise or counter clockwise may be required to align the screw hole with the threaded hole in the pin receptacle body. When these are aligned, the retaining screw is then screwed into the place to secure the housing to the pin receptacle body.
- ⑦ The two cable clamp retainer screws should now be tightened to secure the housing to the microphone cord. If the cutting directions have been carefully followed, the cable clamp should secure to the insulating jacket of the microphone cable.
- ⑧ Upon completion of the microphone plug wiring, connect and secure the microphone plug in the transceiver.

LOCATION OF CONTROLS

FRONT PANEL

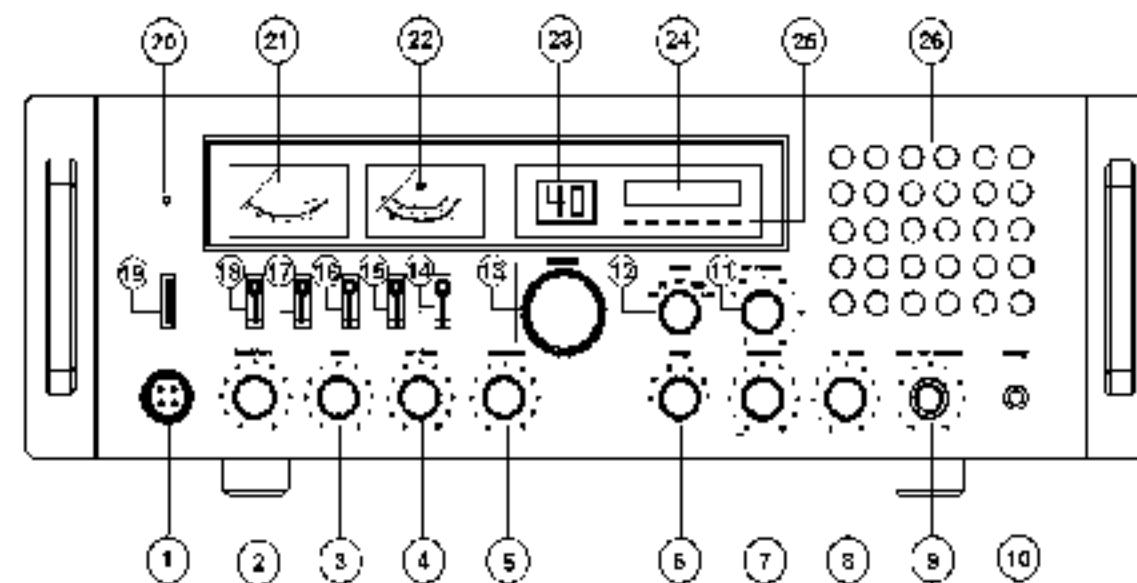

1	Mic. Connector	2	Calibrate	3	Tone
4	RF-Gain	5	Mic. Gain	6	Dimmer
7	Squelch	8	AF Gain	9	Clarifier Fin/Coa
10	Phone Jack	11	RF Power	12	Mode selector
13	Ch. Selector	14	SWR Cal.	15	+10Khz
16	Echo On/Off	17	NB/ANL	18	R. Beep
19	AC Power On Switch	20	Power Indicator	21	Signal Meter
22	SWR/RF Meter	23	Ch. Display	24	Freq. Counter
25	Mode Indicator	26	Built-in Speaker		

LOCATION OF CONTROLS

REAR PANEL

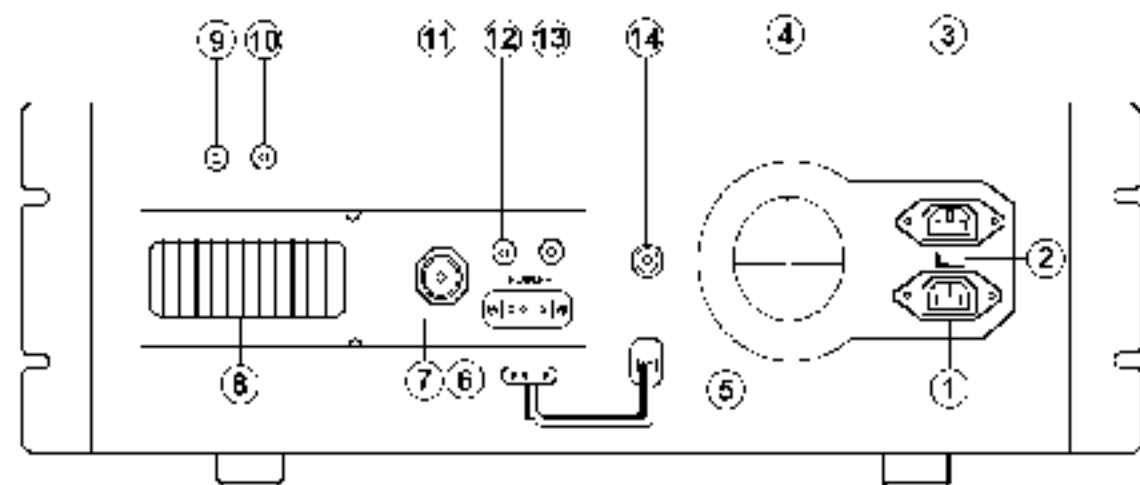

1	AC Power Input plug	9	Freq. Counter Output Jack
2	Input Voltage 110/220V selector	10	Recorder Output Jack
3	Switched AC Power outlet 100W max.	11	Antenna Connector PL-259
4	Cooling Fan	12	P.A. Speaker Jack
5	D.C. Power Cord	13	Ext. Speaker Jack
6	D.C. Power Source Plug	14	C.W. Key Input Jack
7	D.C. Power Input Socket		
8	RF Power Heatsink		

ALTERNATE MICROPHONES AND INSTALLATION

For best results, the user should select a low-impedance dynamic type microphone or a transistorized microphone. Transistorized type microphones have a low output impedance characteristic. The microphones must be provided with a four-lead cable. The audio conductor and its shielded lead comprise two of the leads. The fourth lead is for receive control, and the third is for transmit control. The microphone should provide the functions shown in **FIG. 1** of the microphone wiring schematic.

If the microphone to be used is provided with per-cut leads, they must be received as follows.

- ① Cut leads so that they extend 7/16" beyond the plastic insulating jacket of the microphone cable.
- ② All leads should be cut to the same length. Strip the ends of each wire 1/8" and tin the exposed wire.

Before beginning the actual wiring read carefully, the circuit and wiring information provided with the microphone you select. Use the minimum heat required in soldering the connections. Keep the exposed wire lengths to a minimum to avoid shorting when the microphone plug is reassembled.

MICROPHONE PLUG REASSEMBLING

- ① Remove the retaining screw.
- ② Unscrew the housing from the pin receptacle body.
- ③ Loosen the two cable clamp retainer screws.
- ④ Feed the microphone cable through the housing, knurled ring and washer as shown in **FIG. 3**.
- ⑤ The wires must now be soldered to the pins as indicated in the **FIG. 1**, wiring tables. If a vise or clamping tool is available, it should be used to hold the pin receptacle body during the soldering operation, so that both hands are free to perform the soldering. If a vise or clamping tool is not available, the pin receptacle body can be held in a stationary position by inserting it into the microphone jack of the front panel.

The numbers of the pins of the microphone plug are shown in **FIG. 2**, as viewed from the back of the plug. Before soldering the wire to the pins, pre-tin the wire receptacle of each pin of the plug.

CONTROL FUNCTIONS

FRONT PANEL

- 1 MICROPHONE**
 4 pin Screw-on standard microphone connection. Front panel mounted for easy access. Must be connected to transmit.
- 2 CALIBRATE**
 Allows users to Calibrate the SWR (Standing Wave Ratio) of the antenna used with the radio. This allows the radio to achieve maximum radiated power and the longest range. See page 10, front panel control function 14 SWR/CAL switch.
- 3 TONE**
 Adjust for optimum sound quality output from speaker while on receiving high noise level signal condition.
- 4 RF GAIN CONTROL**
 Use to reduce the gain of the RF amplifier under strong signal conditions.
- 5 MIC. GAIN**
 Adjusts the microphone gain in the transmit and PA modes. This controls the gain to extent that full talk power is available several inches away from the microphone.
- 6 DIMMER SWITCH**
 This switch is used to select the level of brightness of display.
- 7 SQUELCH**
 This control is used to cut off or eliminate receiver background noise in the absence of an incoming signal. For maximum receiver sensitivity it is desired that the control be adjusted only to the point where the receiver background noise or ambient background noise is eliminated. Turn fully counter clockwise then slowly clockwise until the receiver noise disappears. Any signal to be received must now be slightly stronger than the average received noise. Further clockwise rotation will increase the threshold level which a signal must overcome in order to be heard. Only strong signals will be heard at a maximum clockwise setting.

ALTERNATE MICROPHONES SCHEMATIC

FIG. 1 Your transceiver microphone wiring schematic.

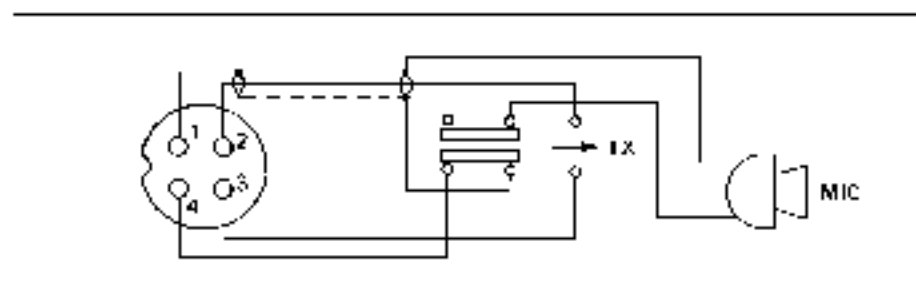

4 Wire Mic. Cable

Pin Number	:	1	2	3	4
Mic Cable Lead	:	AF shield	AF lead	Tx control	Rx control

FIG. 2 Mic plug pin number viewed from rear of pin receptacle

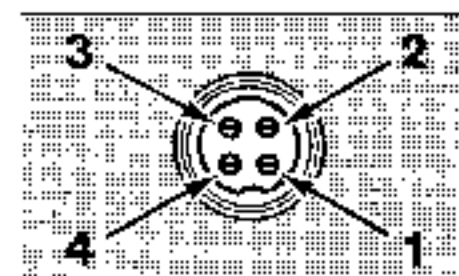
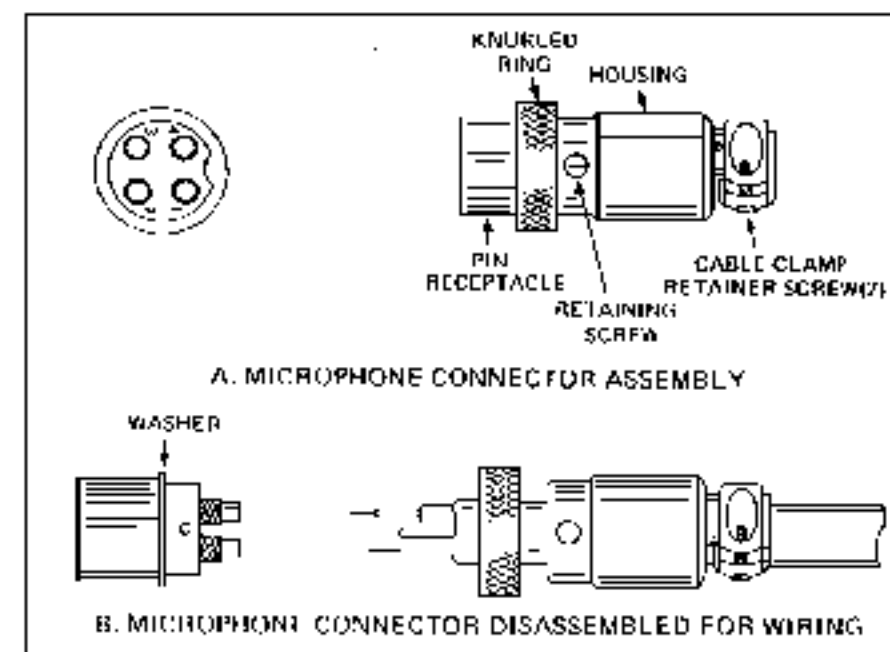

FIG. 3 Microphone plug wiring



CONTROL FUNCTIONS

FRONT PANEL

- 8 **AF GAIN**
Turn clockwise to set the desired listening level. During normal operation, the **AF GAIN** control is used to adjust the output level obtained either at the transceiver speaker or the external speaker, if used.
- 9 **CLARIFIER**
Allows variation of the receiver operating frequencies above and below the assigned frequency. Although this control is intended primarily to tune in SSB signals, it may be used to optimize AM/FM signals as described in the Operating Procedure paragraphs.
- 10 **PHONE**
Accepts headphone with Ø6.5mm mono jack for individual listening.
- 11 **RF POWER CONTROL**
Adjust this control to acquire the RF power output level you desire.
- 12 **MODE SWITCH**
This switch is used to select between **CW / FM / AM / USB / LSB** mode of operation. This changes the mode of operation on both the transmitter and receiver simultaneously. Turn to "Receiving SSB Signals" for a further explanation of single sideband.
- 13 **CHANNEL SELECTOR**
This switch selects any one channel desired. The selected channel appears on the LED readout directly above the Channel Selector Knob.
- 14 **SWR/CAL SWITCH**
Used to calibrate the SWR (Standing Wave Ratio) of the radio. To do so,
 - a) Set the radio into the AM mode.
 - b) Switch the CAL/SWR switch to the CAL position.
 - c) Transmit by pressing the PTT control on the microphone, and adjust the CAL control until the needle reaches the "SET" position on the meter.
 - d) Put the CAL/SWR back into the SWR position, and read the SWR value.

RECEIVING SSB SIGNALS

Thus when a voice is used in place of a whistle or tone, in the proper listening mode the voice will be received correctly whereas in the incorrect mode, the voice will be translated backwards and cannot be made intelligible by the voice lock control. When listening to an AM transmission, a correct sideband is heard in either mode since both upper and lower sideband is received.

Once the desired SSB mode has been selected, frequency adjustment may be necessary in order to make the incoming signal intelligible, the CLARIFIER control allows the operator to vary frequency above and below the exact-center frequency of the received signal. If the sound of the incoming signal is high or low pitched, adjust the operation of the CLARIFIER. Consider it as performing the same function as a phonograph speed control. When the speed is set to high, voices will be high-pitched and if set too low, voices will be low-pitched. Also, there is only *one* correct speed that will make a particular record produce the same sound that was recorded. If the record is played on a turntable that rotated in the wrong direction (opposite sideband) no amount of speed control (CLARIFIER) will produce an intelligible sound.

An AM signal received while listening in one of the SSB modes will produce a steady tone (carrier) in addition to the intelligence, unless the SSB receiver tuned to exactly the same frequency by the CLARIFIER control. For simplicity it is recommend-ed that the AM modes be used to listen to AM signals.

ROGER BEEP

When this switch is placed in the ROGER BEEP position, your radio auto-magically transmits the audio sign at the end of your transmission. The listener can note early that your transmission is over though the sign. Please note that this ROGER BEEP transmits 0.15 second at the moment PTT Switch Knob is off.

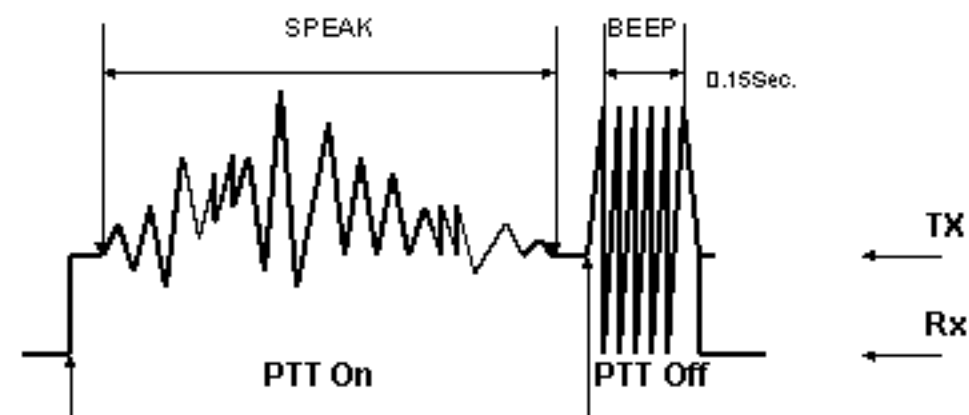

PRESS-TO-TALK MICROPHONE

The PTT switch on the microphone is to control Rx and Tx operation. Press the switch to activate Tx on air and release switch to receive.

When transmitting, hold the microphone two inches from the mouth and speak clearly in a normal "voice". The radios come complete with low impedance (500 Ω) dynamic microphone.

For installation instructions on other microphones, see next section, "ALTERNATIVE MICROPHONES AND INSTALLATION."

OPERATION PROCEDURE TO RECEIVE

- ① Be sure that power source, microphone and antenna are connected to the proper connectors before going to the next step.
- ② Turn unit on by tuning VOLUME control clockwise.
- ③ Set the VOLUME for a comfortable listening level.
- ④ Set the MODE switch to the desired mode.
- ⑤ Listen to the background noise from the speaker. Turn the SQUELCH control slowly clockwise until the noise JUST disappears (no signal should be present). Leave the control at this setting. The SQL. is now properly adjusted. The receiver will remain quiet until a signal is actually received. Do not advance the control too far, or some of the weaker signals will not be heard.
- ⑥ Set the CHANNEL selector switch to the desired channel.
- ⑦ Set the RF gain control fully clockwise for maximum RF gain.
- ⑧ Adjust the CLARIFIER control to clarify the SSB signals or to optimize AM/FM signals.

OPERATING PROCEDURE TO TRANSMIT

- ① Select the desired channel of transmission.
- ② Set the MIC. GAIN control fully clockwise.
- ③ If the Chl., is clear, depress the PTT switch on the Mic., and speak in a normal voice.

CONTROL FUNCTIONS

FRONT PANEL

- ⑮ **+10Khz FREQUENCY SHIFT SWITCH**
When switch is pressed, the frequency is shifted 10Khz up on the following channels. [A] channel can be used by setting this switch to +10Khz position.

NORMAL	3	7	11	15	19
+10Khz	3A	7A	11A	15A	19A

- ⑯ **ECHO On / Off SWITCH**
Activates the ECHO feature of the radio.
- ⑰ **OFF-ANL/NB SWITCH**
When the switch is placed in the ANL / NB position, the RF noise blanker is activated. The RF noise blanker is very effective for repetitive impulse noise as ignition interference.
- ⑱ **ROGER BEEP SWITCH**
This turns on and off the "ROGER BEEP" feature.
- ⑲ **AC POWER SWITCH**
Press in to turn on radio. Press again, and release to turn radio off.
- ⑳ **POWER ON INDICATOR**
This LED lights to indicate the power supply unit is turned on with DC output power.
- ㉑ **Rx SIGNAL METER**
Measures the strength of the Rx incoming signal.
- ㉒ **Tx SWR/RF METER**
Used to measure the strength of the outgoing signal, and also to calibrate the reference level setting before to measure the SWR level of the antenna.
- ㉓ **CHANNEL INDICATOR**
Numbered LED indicates the selected channel you wish to operate on.

CONTROL FUNCTIONS

FRONT PANEL

- 24** **FREQUENCY COUNTER**
This frequency counter indicates the Tx and Rx frequency of the selected channel you wish to operate on.
- 25** **MODE INDICATORS**
These 6 individual LEDs Tx, CW, FM, AM, USB and LSB, lights on to indicate the selected mode is in used.
- 26** **BUILT-IN SPEAKER**
The high quality internal speaker is mounted on front panel which is to provide a clear receiving voice.

REAR PANEL

- 1** **AC POWER INPUT CONNECTOR**
Accepts UL approved USA type 3 pins Socket & Plug with power cord supplied, which is to suit for US standard wall outlet.
- 2** **110/220V INPUT VOLTAGE SELECTOR**
To select the proper input voltage with labeled on top of this switch. Before turn on the AC power switch of the radio, be sure the voltage of your local AC mains supply of the wall outlet.
- 3** **SWITCHED POWER OUTLET**
This power outlet is provided for us as a switched extension AC power source for other AC appliances not exceeds 100W, which to be operated simultaneously with the radio.
- 4** **COOLING FAN**
This is for the cooling system of the built-in switching power supply unit with 12V regulated DC power output, which is the similar type of a computer power supply.

CONTROL FUNCTIONS

REAR PANEL

- 5** **D.C. POWER CORD**
This DC power cord is to transfer the regulated DC power source form the built-in power supply unit, with the red color wire for positive polarity and black is negative.
- 6** **D.C. POWER PLUG**
A detachable 3 pins DC plug is connected with the DC cord from built-in 12V DC power source, and plug in to the main transceiver input connector.
- 7** **D.C. POWER INPUT CONNECTOR**
This panel mount type connector is designed for changeable DC power source input either Internal or External, it accepts the 3 pins DC power plugs provided from this base unit or other external D.C. source input to the main transceiver unit.
- 8** **RF POWER HEATSINK**
This external heat sink is for heat dissipation from the final RF power transistors.
- 9** **FREQ. COUNTER JACK**
This RCA jack is to provide Tx signal for external frequency counter.
- 10** **RECORD OUTPUT JACK**
This RCA jack is to provide AF signals for recording while on Tx or Rx operation, but Tx recording is only valid on ECHO mode operation.
- 11** **ANTENNA CONNECTOR**
Accepts 50Ω coaxial cable with a type PL-259 plug to be connected.
- 12** **P.A. SPEAKER JACK**
Accepts Ø3.5 mono phone plug with external speaker 4~8 Ω / 5W for PA operation, in safety PA operation you must first connect a PA speaker to this jack before select PA mode.
- 13** **EXT. SPEAKER JACK**
Accepts Ø3.5 mono phone plug with external speaker 4~8 Ω / 5W for Rx operation. When external speaker is connected to this jack, the built-in speaker is automatically disconnected.
- 14** **CW KEY INPUT JACK**
Accepts Ø3.5 mono phone jack connected with MORSE key switch unit.