

LUITON LT-298

High Quality AM/FM CB Radio

Owner's Manual



CE 0700 !

To User

Welcome to use LUITON LT-298 AM/FM CB radio, it is a high quality CB radio, which suitable for Poland, Romania, Germany, UK, Italy, Russia bands.

TABLE OF CONTENTS

1. CONTROLS AND REAR PANEL.....	1
2. INSTALLATION.....	4
2.1 Installation of the Main Unit.....	4
2.2 Installation of the Antenna.....	4
2.3 Checking Operation of the Radio.....	5
3. TECHNICAL INDICATORS.....	6

1. CONTROLS AND REAR PANEL

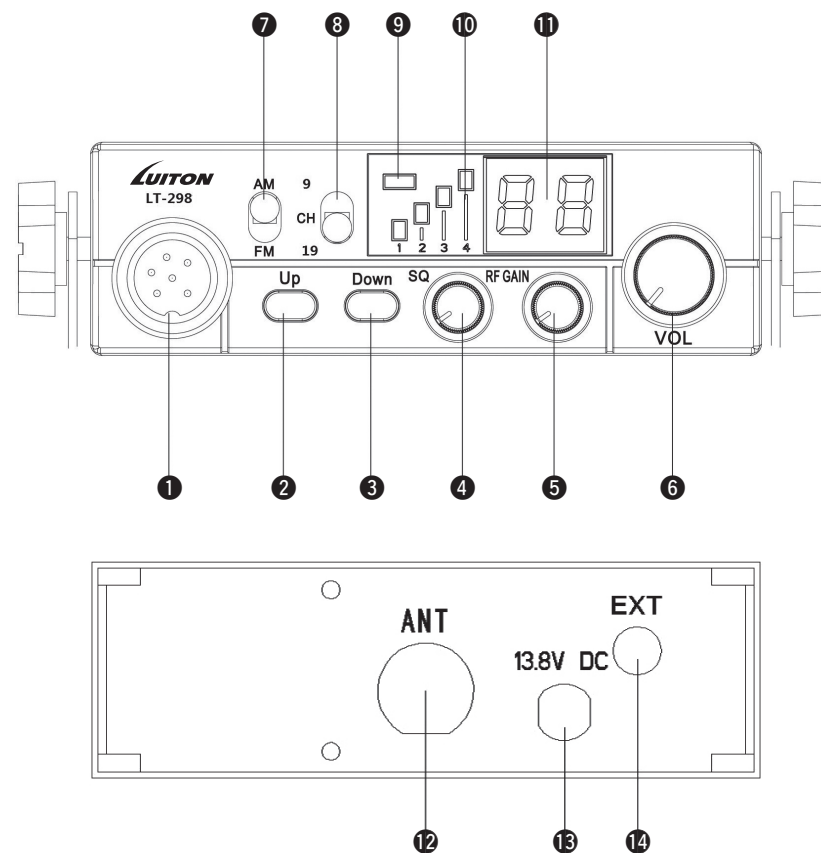

① MICROPHONE connector

Connect the supplied electric condenser microphone to this connector, and then lock it via the ring nut.

② UP KEY

Press this key and channel NO. runs up.

③ DOWN KEY

Press this key channel NO. runs down.

④ SQ knob

The SQUELCH control allows to silent the receiver by cutting the background noise.

Turn the SQUELCH knob anticlockwise until the background noise is cut. Rotate the SQUELCH knob clockwise (SQUELCH ON) to listen to the weakest signals.

5 RF GAIN knob

This transceiver uses a high sensitivity and selectivity receiver circuit. The receiver gain is adjustable with the RF GAIN knob. By rotating the knob anticlockwise, the receiver gain is reduced. It is convenient to reduce the receiver gain in case of very strong signals from local stations. This knob only functions at AM mode.

6 OFF/VOL

This knob controls the radio ON and OFF as well as adjusts the volume. If no signals are being received on the operating channel, it is suggested to turn on the SQUELCH and adjust the volume to the desired level while listening to the background noise. When it is turned on by operating the Volume knob, the radio will remember the channel, frequency, AM or FM used last time.

7 AM/FM mode selector

This switch allows selecting the modulation mode AM or FM.

8 CH9/CH19

This function can select emergency channel CH19 and CH9

Note: In the off state, turn to CH9 can select the frequency of other European countries, and turn to CH can confirm. Restart the radio will prompt the current frequency table.

9 TX and ASQ LED

The indicator light is bi-color, red light and green light, transmitting shows red light, and open ASQ shows green light.

10 RX Signal Meter

4-bar RX signal Meter to monitor the strength of the received signals.

11 DISPLAY

The digital LED display shows the channel.

12 ANTENNA CONNECTOR

Refer to the section INTALLTION OF THE ANTENNA.

13 13.8 VDC POWER CORD

13.8VDC power cord input.

14 EXT (External Speaker) Jack

This jack is for connecting an external speaker.

15 PTT (Push-to-talk) key

Push the button to talk then release to receiving mode.

16 UP key of the microphone

This switch allows increasing a channel number.

17 ASQ on and off

When you press this button, the LED lights for TX and ASQ will light green, then ASQ pen.

18 DN key of the microphone

This switch allows decreasing a channel number.

19 MICROPHONE plug

6-pole microphone plug with locking ring nut, to be connected to socket (1) located on the front side of the radio.

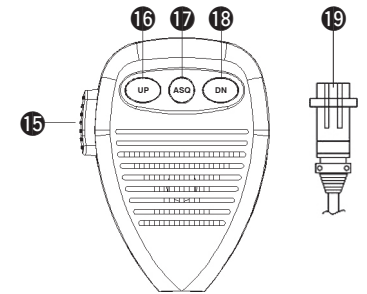

2. INSTALLATION

Before installing the main unit in the vehicle, please check and select the most convenient position, in order that the radio will be easy to reach and comfortable to operate without disturbing or interfering driving. Use the supplied bracket and hardware to install the radio.

The bracket screws must be well tightened to avoid looseness as the vehicle vibrates. The car mounting bracket can be installed over or below the radio and the radio may be inclined as desired according to the specific type of installation (under dashboard or track cabin roof installation).

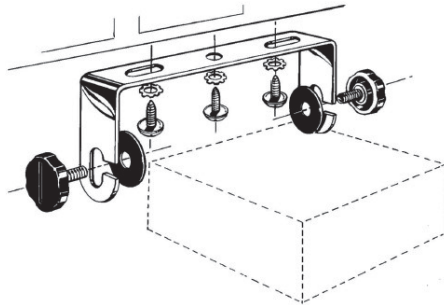

2.1 INSTALLATION OF THE MAIN UNIT

Before connecting the radio to the vehicle electric system, please make sure the radio is powered off with the **OFF/VOL 6** knob completely turned anticlockwise at OFF position. The DC power cable of the radio includes a fuse holder with fuse located on the red positive (+) wire. Please connect the DC power cable to the vehicle electric system with special attention to correct polarity, even if the radio is protected against polarity inversion. Connect the red wire to the positive (+) pole and the black wire to the negative (-) pole of the vehicle electric system. Please make sure that the wires and terminals are firmly connected, to prevent cables from disconnecting or causing short circuits.

2.2 INSTALLATION OF THE ANTENNA

A specific mobile antenna adjusted for 27 MHz frequency range must be used. The antenna installation must be done by a qualified technician or service center. Please install the antenna carefully on the

vehicle with proper connection to ground. Before connecting the antenna to the radio, it is necessary to check the correct operation of the antenna with low standing wave ratio (S.W.R.) via adequate instruments. If not, the transmitter circuit of the radio could be damaged. The antenna usually must be installed on the highest part of the vehicle, free from obstacles and as far away as possible from any source of electric or electromagnetic noise. The RF antenna coaxial cable must not be damaged or pressed on its way between antenna and the radio. The correct operation of the antenna and the low standing wave ratio (S.W.R.) must be checked periodically. Connect the RF antenna coaxial cable to the **antenna connector 15**, located on the rear side of the radio.

2.3 CHECKING OPERATION OF THE RADIO

Once radio has been connected to the vehicle electric system and to the antenna, the correct operation of the system should be checked. Please proceed as following:

- 1) Check that the power cable is correctly connected.
- 2) Check that the RF antenna coaxial cable is properly connected.
- 3) Connect the microphone to the **connector 1** that is on the front side of the radio.
- 4) Rotate the **SQUELCH 4** knob anticlockwise.
- 5) Turn radio on by the **OFF/VOL 6** knob and adjust volume to the desired level.
- 6) Select the desired channel with the up/down key on the front side of the radio.
- 7) Rotate the **SQUELCH 4** knob clockwise to cut the background noise.
- 8) Press the PTT key to transmit and release it to receive.
- 9) Check the level of the received and transmitted signals on the 4 bar RX signal Meter and TX LED. The transceiver will work correctly.

3. TECHNICAL INDICATORS

General	
Channels	40 AM/FM
Frequency range	26.960 – 27.400MHz
Frequency control	P.L.L.
Frequency Tolerance	±0.005%
Operating temperature	-20°/+55°C
DC input voltage	13.8Vdc ±15%
Size	115 (L) x 38 (A) x 150 (P) mm
Weight	0.8 kg
Receiver	
System	CPU controlled Double conversion super
IF	1° 10.7 MHz / 2° 450 KHz
Sensitivity	-120dBm for 12dB SINAD (FM)
	-107dBm for 12dB SINAD (AM)
Audio output	@10% THD 2.5W at 8 ohm
Audio distortion	<8% at 1 KHz
Image rejection	65dB
Adjacent channel	85dB
Signal ise ratio	45dB
Current drain	220mA (stand-by)
Transmitter	
System	CPU controlled P.L.L. synthesizer
Maximum RF power	4W at 13.2Vdc
Modulation	85% to 90% (AM)
	2KHz ±0.2 KHz (FM)
ANT impedance	50 ohm unbalanced
Current drain	1500mA (at no modulation)

**Specifications and features are subject to change without notice.*



Bond Telecom Co. Ltd.
Website: www.luiton.com