

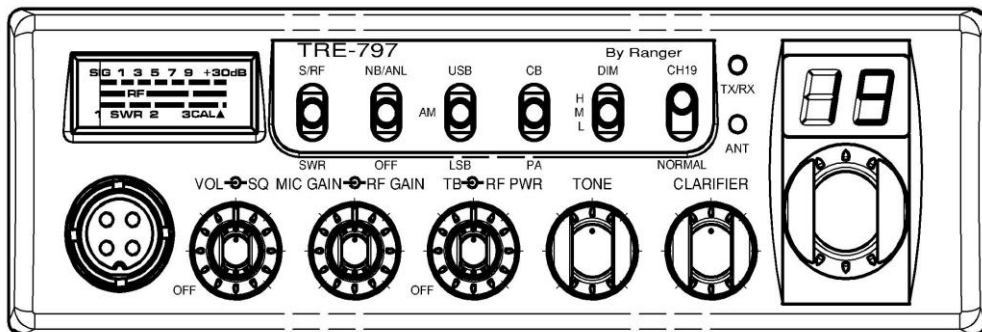

# TRE797



**AM / SSB Two Way  
Citizens Band Mobile Transceiver**

**OWNER'S MANUAL**

# TABLE OF CONTENTS

PAGE

## CHAPTER 1

<b>Specifications</b> .....	2
-----------------------------	---

## CHAPTER 2

<b>Installation</b> .....	3
Installing The Radio .....	3
Ignition Noise Interference .....	4
Antenna .....	4
External Speaker .....	4
Public Address .....	4

## CHAPTER 3

<b>Operation</b> .....	5
Front Panel .....	5
Rear Panel .....	8
Frequency Chart .....	9
Procedure to Receive and Transmit .....	10
Receiving SSB Signals .....	11
Alternate Microphone and Installation .....	13
Maintenance And Adjustment .....	16
A Few Rules That Should Be Obeyed .....	17
How Your CB Can Serve You .....	17
Use Channel 9 For Emergency Message Only .....	18

# CHAPTER 1 SPECIFICATIONS

## GENERAL

Model	TRE 797
Channels	40
Frequency Range	26.965 ~ 27.405 MHz
Emission	AM/USB/LSB
Frequency Control	Phase-Lock-Loop (PLL) Synthesizer
Frequency Stability	0.001%
Temperature Range	-30°C to +50°C
Antenna Impedance	50 Ohms
Antenna Connectors	Standard SO-239 type
Input Voltage	13.8V DC
Size	7 1/4" (W) x 9" (D) x 2 1/4" (H)
Weight	3.553 lbs.

## TRANSMITTER

RF Power Output	AM: 4W; USB/LSB: 12W PEP
Spurious Emission	> -60 dB
Unwanted Sideband	-50 dB
Audio Distortion	< 5%
Frequency Response	300 to 2500 Hz
Microphone	Dynamic

## RECEIVER

Sensitivity for 10 dB (S+N)/N	AM: < 0.5 uV ; USB/LSB: < 0.25 uV
Squelch Sensitivity	< 0.5 uV
Selectivity	> -50 dB
Image Rejection	> 60 dB
Hum & Noise	> -40 dB
AGC Figure of Merit	50 mV for 10 dB Change in Audio Output
Audio Power Output	2.5W @ 10% Distortion
Audio Response	300 to 2500 Hz

(SPECIFICATIONS SUBJECT TO CHANGE WITHOUT NOTICE)

## CHAPTER 2 INSTALLATION

### INSTALLING THE RADIO

Choose a convenient location for operation that does not interfere with driver or passenger. This radio is supplied with a universal mounting bracket. When mounting the bracket and radio to your car, make sure it is mechanically strong. Also, provide a good electrical grounding connection to the chassis of vehicle. Proceed as follows to install the radio.

1. Locate a convenient area in your vehicle for the installation of the radio. Hold the mounting bracket with the radio in the location where the radio is to be installed. Make sure nothing will interfere with either the radio or the mounting bolts. Mark and then drill holes for the mounting bracket.
2. Most radio antennas come equipped with a PL-259 plug. Connect this plug to the ANT. Jack in the rear of the radio.
3. Extending from the rear of the radio is a fused red and black wire for the DC connections to the vehicle's electrical system. For best performance, it is strongly recommended that the red lead be taken directly to the positive terminal on the vehicle's battery and the black lead be connected to the nearest chassis ground. (Note: *This radio is designed for vehicles with negative ground systems.*)

Connections should be made using appropriate "crimp on" lugs of a size large enough to make good contact with the bolt used to fasten to the battery and the chassis ground. It is a good safety idea to install a second fuse that would provide protection in case the red wire was to "fray" or get pinched and short to the body of the vehicle, somewhere between the battery and the radio.

Poor power connections cause supply voltage drops that can substantially decrease the performance of your radio. A good DC connection is probably one of the most important things for getting the best transmitter performance and in some cases, least receiver noise.

4. Mount the microphone bracket near the radio in an easily accessible spot using the two screws provided.

## **IGNITION NOISE INTERFERENCE**

With weak signals, you may experience interference of the signal by background noise. This radio has NB and ANL circuits which will help reduce background noise from sources such as your ignition system. However, background electrical noise may come from several sources and all noise may not be eliminated. With extremely weak signals, you can operate this radio with the engine turned off, which should improve reception. If the ignition noise level is too high to allow proper operation under most conditions, you should have your installation of the radio checked by a qualified technician.

## **ANTENNA**

This radio has a jack in the rear for a standard PL-259 antenna plug. If you are looking for the most range for your transmission, use a vertically polarized, quarter-wave length antenna. If antenna height is a problem, you may use a shorter, loaded-type whip antenna although you can expect some loss of transmission range.

To improve performance, your antenna should be matched to your radio. Your antenna can be adjusted so that it matches your radio.

## **EXTERNAL SPEAKER**

The external speaker jack (EXT SP.) on the rear panel is used for remote receiver monitoring. The external speaker should have 8 ohms impedance and be able to handle at least 4 watts. When the external speaker is plugged in, the internal speaker is disconnected.

## **PUBLIC ADDRESS**

To use the Public Address (PA) function, first connect an external speaker to the PA. SP. Jack on the rear of the radio. See the above specifications for a proper external speaker. Keep the speaker away from the microphone to avoid acoustic feedback.

# CHAPTER 3 OPERATION

## CONTROL FUNCTIONS

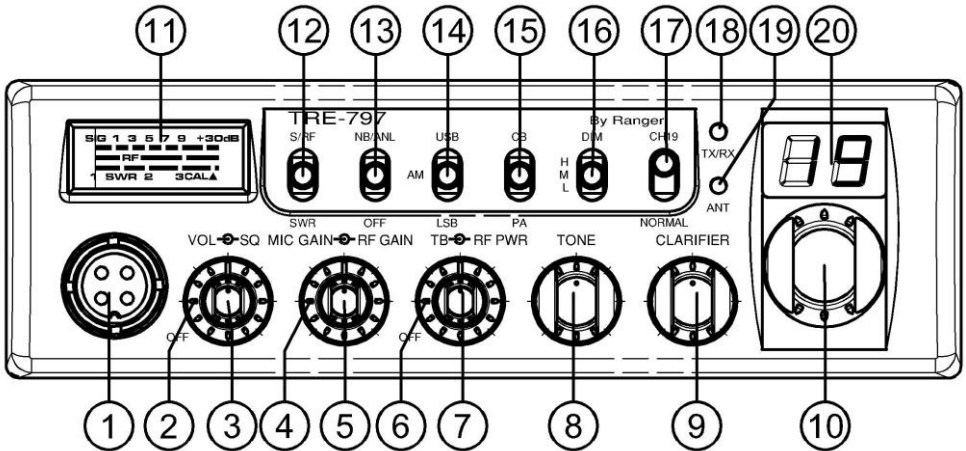

## FRONT PANEL

- 1. MICROPHONE JACK:** Used to connect microphone for voice source.
- 2. SQUELCH CONTROL:** This knob is used to eliminate background noise being heard through the receiver, which can be disturbing when no transmissions are being heard through the receiver. To use this feature, turn the knob fully counterclockwise and then turn clockwise slowly until the background noise is just eliminated. Further clockwise rotation will increase the threshold level which a signal must overcome in order to be heard. Only strong signals will be heard at a maximum clockwise setting.
- 3. ON/OFF VOLUME CONTROL:** This knob controls the volume and power to the radio. To turn radio on, rotate the knob clockwise. Turning the knob further will increase the volume of the receiver.
- 4. RF GAIN CONTROL:** This control is used to reduce the gain of the RF (receive) amplifier under strong signal conditions.

5. **MIC GAIN CONTROL:** Adjusts the microphone gain in the transmit and PA modes. This controls the gain to the extent that full talk power is available several inches away from the microphone. In the Public Address (PA) mode, the control functions as the volume control.
6. **RF POWER CONTROL:** This control allows the user to adjust RF power output.
7. **TALKBACK CONTROL:** Adjust this knob for desired volume of Talkback. This is used to monitor your own voice. For example, you could use this feature to compare different microphones.
8. **tone CONTROL:** This control changes tone quality in receive only. In clockwise rotation, treble is increased and in counter clockwise rotation, bass is increased.
9. **CLARIFIER CONTROL:** Allows tuning of the receive frequency above or below the channel frequency by up to 1.0KHz. Although this control is intended primarily to tune in SSB signals, it may be used to optimize AM signals.
10. **CHANNEL SELECTOR:** This control is used to select the desired transmit and receive channel.
11. **FRONT PANEL METER:** The front panel meter allows the user to monitor incoming signal strength, RF output power, SWR level.
12. **S-RF/SWR SWITCH:** In the S-RF position, the meter swings Proportionally to the strength of the received signal. When transmitting the meter indicates relative RF output power. When in the SWR position, the Standing Wave Ratio (SWR) of your antenna. There are no adjustments because the SWR circuit this radio calibrates itself automatically.
13. **NB/ANL/OFF SWITCH:** In the NB/ANL position, the RF Noise Blanker and the automatic Noise Limiter in the audio circuits are also activated. The Noise Blanker is very effective in eliminating repetitive impulse noise such as ignition interference.
14. **MODE SWITCH:** This control allows you to select one of the following operating modes: AM/USB/LSB.
15. **PA / CB SWITCH:** Select the mode of operation. In the PA position, the radio acts as public address amplifier. Your voice will come out of the speaker that is plugged into the PA. SP. jack on the rear panel. The radio does not operate when

you are in the PA mode. In the CB position, the PA function is disabled and the radio will transmit and receive on the speaker that is connected.

16. **DIM. H/M/L:** Controls the brightness of the meter, channel display and RX/TX LED.
17. **CH19/NORMAL SWITCH:** Channel 19 switch is used for instant to information channel 19.
18. **RX/TX LED:** This LED is white during receive and red during transmit.
19. **SWR LED:** This LED lights red when your SWR is higher than about 3:1. This is not an exact indicator of 3:1 SWR, but it is an indication that you should check your SWR reading.
20. **CHANNEL DISPLAY:** The channel display indicates the current selected channel.

# REAR PANEL

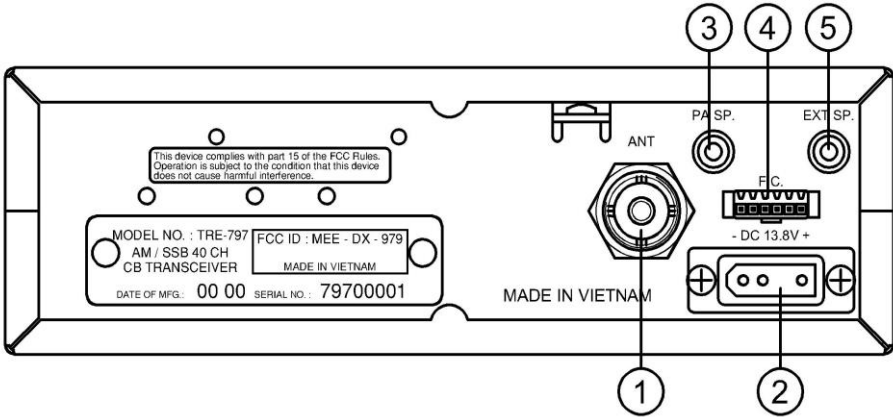

1. **ANTENNA:** This jack accepts a 50 ohm coaxial cable with a PL-259 type plug.
2. **DC POWER:** This jack accepts the 13.8V DC power cable with built-in fuse. The power cord provided with the radio has a black and red wire. The black goes to negative and red goes to positive.
3. **PA SP:** This jack is for PA operation. Before operating, you must first connect a PA speaker (8 ohms, 4W) to this jack.
4. **F.C.:** This jack is used to connect the optional Galaxy FC347 six-digit frequency counter. All connections, including DC power, are provided to the FC347 through this jack.
5. **EXT. SP:** This jack accepts a 4 to 8 ohm, 5 watt external speaker. When the external speaker is connected to this jack, the built-in speaker will be disabled.

# FREQUENCY CHART

Channel	Channel Frequency	Channel	Channel Frequency
1	26.965 MHz	21	27.215 MHz
2	26.975 MHz	22	27.225 MHz
3	26.985 MHz	23	27.255 MHz
4	27.005 MHz	24	27.235 MHz
5	27.015 MHz	25	27.245 MHz
6	27.025 MHz	26	27.265 MHz
7	27.035 MHz	27	27.275 MHz
8	27.055 MHz	28	27.285 MHz
9	27.065 MHz	29	27.295 MHz
10	27.075 MHz	30	27.305 MHz
11	27.085 MHz	31	27.315 MHz
12	27.105 MHz	32	27.325 MHz
13	27.115 MHz	33	27.335 MHz
14	27.125 MHz	34	27.345 MHz
15	27.135 MHz	35	27.355 MHz
16	27.155 MHz	36	27.365 MHz
17	27.165 MHz	37	27.375 MHz
18	27.175 MHz	38	27.385 MHz
19	27.185 MHz	39	27.395 MHz
20	27.205 MHz	40	27.405 MHz

## **PROCEDURE TO RECEIVE AND TRANSMIT**

### **A. MICROPHONE**

The push-to-talk switch on the microphone controls the receiver and transmitter. Press the switch and the transmitter is activated, release switch to receive. When transmitting, hold the microphone two inches from your mouth and speak clearly in a normal voice. This transceiver comes complete with a low impedance dynamic microphone.

### **B. PROCEDURE TO RECEIVE**

1. Be sure that power source, microphone and antenna are connected to the proper connectors before going to the next step.
2. Turn **VOL** knob clockwise to apply power to the radio.
3. Set the **VOL** for a comfortable listening level.
4. Set the **MODE** switch to the desired mode.
5. Listen to the background noise from the speaker. Turn the **SQ** knob slowly clockwise until the noise just disappears. The **SQ** is now properly adjusted. The receiver will remain quiet until a signal is actually received. Do not advance the control too far or some of the weaker signals will not be heard.
6. Set the **CHANNEL** selector switch to the desired channel.
7. Adjust **CLARIFIER** control to clarify the SSB signals or to optimize AM signals.

### **C. PROCEDURE TO TRANSMIT**

1. Select the desired channel of operation.
2. Set the **MIC GAIN** control fully clockwise.
3. If the channel is clear, depress the push-to-talk switch on the microphone and speak in a normal voice.

## RECEIVING SSB SIGNALS

There are three types of signals presently used for communications in the Citizen Band: AM, USB and LSB. When the MODE switch on your unit is placed in the AM position, only standard double-side band, full carrier signals will be detected. An SSB signal may be recognized while in the AM mode by its characteristic "Donald Duck" sound and the inability of the detector to produce an intelligible output. The USB and LSB modes will detect upper side band and lower side band respectively, and standard AM signals.

SSB reception differs from standard AM reception in that an SSB receiver does not require a carrier or opposite side band to produce an intelligible signal. A single-side band transmitted signal consists only of the upper or the lower side band and no carrier is transmitted. The elimination of the carrier from the AM signal helps to eliminate the biggest cause of whistles and tones heard on channels which make even moderately strong AM signals unreadable. Also, SSB takes only half the space of an AM channel, therefore two SSB conversations will fit into each channel, expanding the 40 AM channels to 80 SSB channels. The reduction in channel space required also helps in the receiver because only half of the noise and interference can be received with 100% of the SSB signal.

An SSB signal may be received only when the listening receiver is functioning in the same mode. In other words, an upper side band signal (USB) may be made intelligible only if the receiver is functioning in the USB position.

If a lower side band (LSB) signal is heard when the receiver is in the USB mode, no amount of tuning will make the signal intelligible. The reason for this may be understood if you consider that when the modulation is applied to the transmitter's microphone in the USB mode, the transmitter output frequency is increased whereas in the LSB mode the transmitter's output frequency is decreased.

The result in listening to the receiver is that when the MODE switch is in the proper position (either USB or LSB), a true reproduction of a single tone of modulation will result, and if the tone is increased in frequency (such as a low-pitched whistle or a high-pitched whistle) you will hear the increase in the output tone of the receiver. If the incorrect mode is selected, an increase in tone of a whistle applied to the transmitter will cause a decrease in the resultant tone from the receiver.

Thus when a voice is used in place of a whistle or tone, in the proper listening mode the voice will be received correctly whereas in the incorrect mode, the voice will be translated backwards and cannot be made intelligible by the CLARIFIER control. When listening to an AM transmission, a correct side band is heard in either mode since both upper and lower side bands are received.

Once the desired SSB mode has been selected, frequency adjustment may be necessary in order to make the incoming signal intelligible. The CLARIFIER control allows the operator to vary frequency above or below the exact frequency of the channel. If the sound of the incoming signal is high or low pitched, adjust the operation of the CLARIFIER.

Consider it as performing the same function as a phonograph speed control. When the speed is set too high, voices will be high-pitched and if set too low, voice will be low-pitched. Also, there is only one correct speed that will make a particular record produce the same sound that was recorded. If the record is played on a turntable that is rotated in the wrong direction (opposite side band) no amount of speed control (CLARIFIER) will produce an intelligible sound.

An AM signal received while listening in one of the SSB modes will produce a steady tone (carrier) in addition to the intelligence, unless the SSB receiver is tuned to exactly the same frequency by the CLARIFIER control. For simplicity, it is recommended that the AM modes be used to listen to AM signals.

# ALTERNATE MICROPHONES AND INSTALLATION

For best results, the user should select a low-impedance dynamic type microphone or a transistorized microphone. Transistorized type microphones have low output impedance characteristics. The microphones must be provided with a four-lead cable. The audio conductor and its shielded lead comprise two of the leads. The third lead is for transmit control and fourth is for receiving control.

The microphone should provide the functions shown in the schematic below.

## 4 WIRE MIC CABLE

<u>Pin Number</u>	<u>Mic Cable Lead</u>
1	Audio Shield
2	Audio Lead
3	Transmit Control
4	Receive Control

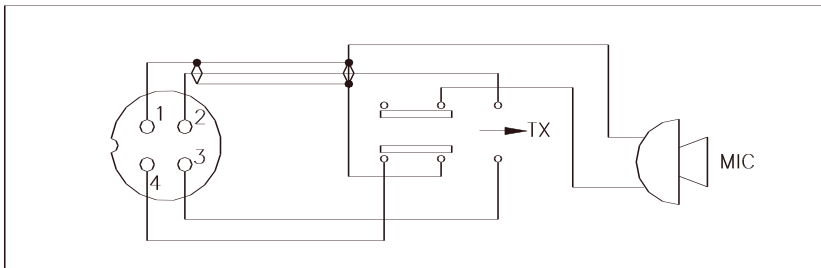
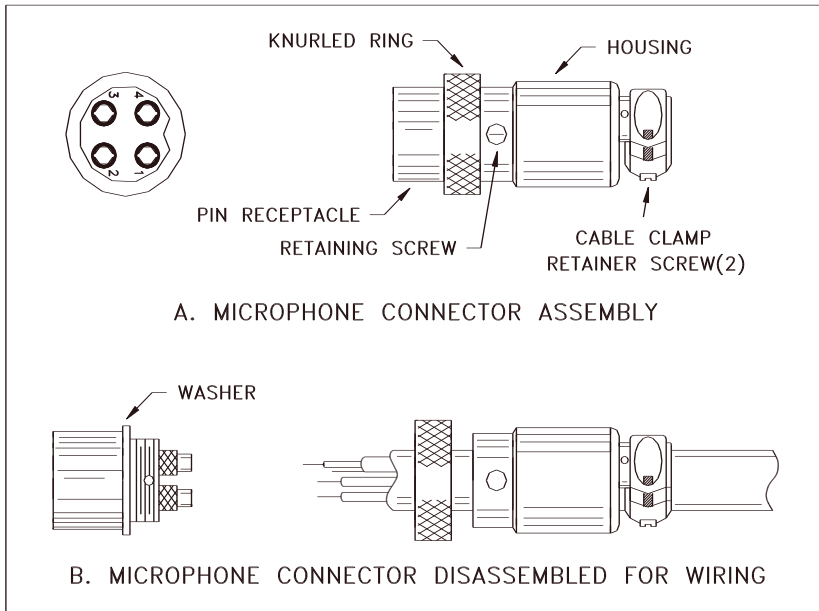

**Fig. 1** Your transceiver microphone schematic.

If the microphone to be used is provided with pre-cut leads, they must be revised as follows.

1. Cut leads so that they extend 7/16" beyond the plastic insulating jacket of the microphone cable.
2. All leads should be cut to the same length. Strip the ends of each wire 1/8" and tin the exposed wire.

Before beginning the actual wiring, read carefully the circuit and wiring information provided with the microphone you select. Use the minimum heat required in soldering the connections. Keep the exposed wire lengths to a minimum to avoid shorting when the microphone plug is reassembled.

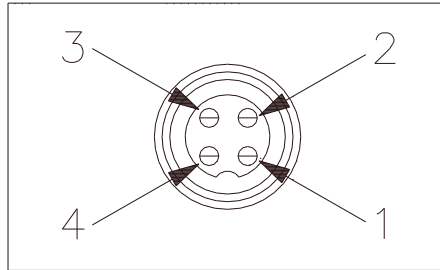

**Fig. 2** Microphone plug wiring

To wire the microphone cable to the plug provided, proceed as follows:

1. Remove the retaining screw.
2. Unscrew the housing from the pin receptacle body.
3. Loosen the two cable clamp retainer screws.
4. Feed the microphone cable through the housing, knurled ring and washer as shown Figure 2.

- The wires must now be soldered to the pins as indicated in the above wiring tables. If a vise or clamping tool is available it should be used to hold the pin receptacle body during the soldering operation, so that both hands are free to perform the soldering. If a vise or clamping tool is not available, the pin receptacle body can be held in a stationary position by inserting it into the microphone jack on the front panel. The numbers of the microphone plug are shown in Fig. 3, as viewed from the back of the plug. Before soldering the wire to the pins, pre-tin the wire receptacle of each pin of the plug.



**Fig. 3** Microphone plug pin numbers viewed from rear of pin receptacle.

- Be sure that the housing and the knurled ring of Figure 2 are pushed back onto the microphone cable before starting to solder. If the washer is not captive to the pin receptacle body, make sure that it is placed on the threaded portion of the pin receptacle body before soldering.
- If the microphone jack is used to hold the pin receptacle during soldering operation, best results are obtained when the connections to pin 1 and 3 are made first and then the connections to pins 2 and 4. Use a minimum amount of soldering and be careful to prevent excessive solder accumulation on pins, which could cause a short between the pin and the microphone plug housing.
- When all soldering connections to the pins of the microphone are completed, push the knurled ring and the housing forward and screw the housing onto the threaded portion of the pin receptacle body. Note the location of the screw clearance hole in the plug housing with respect to the threaded hole in the pin receptacle body. When the housing is completely threaded into the pin receptacle body, a final fraction of a turn either clockwise or counterclockwise may be required to align the screw hole with the threaded hole in the pin receptacle body. When these are aligned, the retaining screw is then screwed into place to secure the housing to the pin receptacle body.

9. The two cable clamp retainer screws should now be tightened to secure the housing to the microphone cord. If the cutting directions have been carefully followed, the cable clamp should secure to the insulation jacket of the microphone cable.
10. Upon completion of the microphone plug wiring, connect and secure the microphone plug in the transceiver.

## **MAINTENANCE AND ADJUSTMENT**

This transceiver is specifically designed for the environment encountered in mobile installations. The use of all solid state circuitry and its light weight result in high reliability. Should a failure occur, however, replace parts only with identical parts. Do not substitute.

### **NOTE**

If the performance described in the OPERATION section is not obtained, review the operating instructions to insure that proper procedures were followed.

### **FCC WARNING**

All transmitter adjustments other than those provided on front panel by the manufacturer must be made by or under the supervision of the holder of an FCC issued general radio telephone operator's license.

## **A FEW RULES THAT SHOULD BE OBEYED**

1. You are not allowed to carry on a conversation with another station for more than five minutes at a time without taking a one-minute break, to give others a chance to use the channel.
2. You are not allowed to blast others off the air by over-powering them with illegally amplified transmitter power, or illegally high antennas.
3. You can't use the transceiver to promote illegal activities.
4. You are not allowed to use profanity.
5. You may not play music in your transceiver.
6. You may not use your transceiver to sell merchandise or professional services.

## **HOW YOUR CB CAN SERVE YOU**

1. Warn of traffic tie-ups ahead.
2. Provide weather and road information.
3. Provide help fast in event of emergency or breakdown.
4. Suggest good spots to eat and sleep.
5. Make long trips more interesting, and help keep you awake.
6. Provide direct contact with your office or home.
7. Make friends for you as you travel.
8. Provide "local information" to find your destination.
9. Help law enforcement officers by reporting drunk and reckless drivers.

## **USE CHANNEL 9 FOR EMERGENCY MESSAGES ONLY**

The FCC gives the following examples of permitted and prohibited types of communications for use in an emergency. These are guidelines and are not intended to be all inclusive.

<b>Permitted</b>	<b>Example Message</b>
YES	“A tornado sighted six miles north of town.
NO	“This is observation post number 10. No tornado sighted.
YES	“I am out of gas on interstate 95”
NO	“I am out of gas in my driveway”
YES	“There is a four-car collusion at exit 10 on the Beltway, send police and ambulance.”
NO	“traffic is moving smoothly on the Beltway”
YES	“Base to Unit 1, the weather Bureau has just issued a thunder storm warning. Bring the sailboat into port.”
NO	“Attention all motorists. The weather Bureau advises that the snow tomorrow will accumulate 4 to 6 inches.
YES	“There is a fire in the building on the corner of 6th and Main Streets.”
NO	“This is Halloween patrol unit number 3. Everything is quiet here.”











