



TEXAS RANGER™

TR-396F



CITIZENS BAND TRANSCEIVER
AM MOBILE WITH FREQUENCY COUNTER

OWNER'S MANUAL

Downloaded from www.cbradio.nl

Printed In Malaysia
AT148N082D
980610

TABLE OF CONTENTS

CHAPTER 1	PAGE
Specifications	2
CHAPTER 2	
Frequency List	3
CHAPTER 3	
Installation	4
Installing The Radio	4
Ignition Noise Interference	5
Antenna	5
Adjusting The Antenna for Optimum SWR	5
External Speaker	6
CHAPTER 4	
Operation	7
Front Panel	7
Rear Panel	10
Procedure to Receive and Transmit	11
Microphone Installation And Substitutes	12
Limited Warranty	Inside Back Cover

CHAPTER 1 SPECIFICATIONS

GENERAL

Frequency Range	26.965 - 27.405 MHz
Emission	40 AM
Frequency Control	Phase-Lock-Loop Synthesizer
Frequency Stability	0.001%
Temperature Range	-30 °C to +50 °C
Input Voltage	13.8 V DC
Antenna Impedance	50 Ohms
Size	7 7/8" (W) x 9 1/4" (D) x 2 3/8" (H)
Weight	5.0 lb.

TRANSMITTER

RF Power Output	4W
Frequency Response	300 to 2500 Hz
Audio Distortion	10 %
Spurious Emission	Better than -55 dB
Carrier Emission	Better than -55 dB

RECEIVER

Sensitivity for 10 dB S+N/N	0.5 uV
Squelch Sensitivity	Less than 0.5 uV
Audio Power Output	2W @ 10% Distortion
Image Rejection Ratio	-65 dB
AGC Figure of Merit	100 mV for 10 dB Change in Audio Output
Audio Response	300 to 2500 Hz

(SPECIFICATIONS SUBJECT TO CHANGE WITHOUT NOTICE)

CHAPTER 2 FREQUENCY LIST

Channel	Channel Frequency	Channel	Channel Frequency
1	26.965 MHz	21	27.215 MHz
2	26.975 MHz	22	27.225 MHz
3	26.985 MHz	23	27.255 MHz
4	27.005 MHz	24	27.235 MHz
5	27.015 MHz	25	27.245 MHz
6	27.025 MHz	26	27.265 MHz
7	27.035 MHz	27	27.275 MHz
8	27.055 MHz	28	27.285 MHz
9	27.065 MHz	29	27.295 MHz
10	27.075 MHz	30	27.305 MHz
11	27.085 MHz	31	27.315 MHz
12	27.105 MHz	32	27.325 MHz
13	27.115 MHz	33	27.335 MHz
14	27.125 MHz	34	27.345 MHz
15	27.135 MHz	35	27.355 MHz
16	27.155 MHz	36	27.365 MHz
17	27.165 MHz	37	27.375 MHz
18	27.175 MHz	38	27.385 MHz
19	27.185 MHz	39	27.395 MHz
20	27.205 MHz	40	27.405 MHz

CHAPTER 3 INSTALLATION**INSTALLING THE RADIO**

Choose a convenient location for operation that does not interfere with the driver or passenger. This radio is supplied with a universal mounting bracket. When mounting the bracket and radio to your car, make sure it is mechanically strong. Also, provide a good electrical grounding connection to the chassis of the vehicle. Proceed as follows to install the radio:

1. Locate a convenient area in your vehicle for the installation of the radio. Hold the mounting bracket with the radio in the location where the radio is to be installed. Make sure nothing will interfere with either the radio or the mounting bolts. Mark and then drill holes for the mounting bracket.
2. Most radio antennas come equipped with a PL-259 plug. Connect this plug to the ANT. jack in the rear of the radio.
3. Extending from the rear of the radio is a red DC power wire. Locate a +13.8V DC power source by tracing the power wire from your AM radio to the accessory box in your vehicle. Connecting the power wire from your radio to this box allows operation of your radio without the engine running and also prevent battery drain through accidental failure to turn your radio off when away from the vehicle.
4. Connect the black lead to -13.8V DC. You may connect the black wire to the chassis of the vehicle or other ground as long as it is a negative ground. Make sure there is a good contact to bare metal. As a safety precaution, you should also attach a ground wire to a part of the radio chassis, if the radio is not mounted to a metal surface.
5. Mount the microphone bracket near the radio in an easily accessible spot using the two screws provided.

IGNITION NOISE INTERFERENCE

With weak signals, you may experience interference of the signal by background noise. This radio has NB and ANL controls which will help reduce background noise from sources such as your ignition system. However, background electrical noise may come from several sources and all noise may not be eliminated. With extremely weak signals, you can operate this radio with the engine turned off, which should improve reception. If the ignition noise level is too high to allow proper operation under most conditions, you should have your installation of the radio checked by a qualified technician.

ANTENNA

This radio has a jack in the rear for a standard PL-259 antenna plug. If you are looking for the most range for your transmission, use a vertically polarized, quarter-wavelength antenna. If antenna height is a problem, you may use a shorter, loaded-type whip antenna although you can expect some loss of transmission range.

To improve performance, your antenna should be matched to your radio. Your antenna can be adjusted so that it matches your radio.

ADJUSTING THE ANTENNA FOR OPTIMUM SWR

Before using your transmitter, you should adjust the antenna so that it matches your radio. This is done by adjusting the length of your antenna. Generally, a lower channel, such as Channel 1 requires a longer antenna length than a higher channel, such as Channel 40

1. ANTENNA WITH SET SCREWS

1. Extend the antenna to its full length. Tighten the set screws just enough to hold the position, yet allowing easy adjustment of the antenna's length.
2. Tune the radio to Channel 20 and press the Push-To-Talk (PTT) switch. Shorten the antenna gradually while watching the SWR meter. You will notice the SWR reading decrease and then start to rise again. The point at which the SWR meter start to rise is the proper length of the antenna for Channel 20. You may want to repeat the tuning process to fine tune the length of the antenna.
3. At this point Channel 1 and Channel 40 should have the same reading on the SWR meter. The meter should read 1.5 or below if the antenna is properly matched to the radio.

- 5 -

2. ANTENNA WHICH MUST BE CUT TO TUNE

1. This type of antenna is tuned by trimming the length of the antenna to the proper length. Be careful to cut in small increments so that you do not trim too much at once.
2. Tune the radio to Channel 20, and press the Push-To-Talk (PTT) switch. Shorten the antenna gradually while watching the SWR meter. You will notice the SWR reading decrease and then start to rise again. The point at which the SWR meter start to rise is the proper length of the antenna for Channel 20. You may want to repeat the tuning process to fine tune the length of the antenna.
3. At this point Channel 1 and Channel 40 should have the same reading on the SWR meter. The meter should read 1.5 or below if the antenna is properly matched to the radio.

If you are having trouble matching the antenna to the radio, check to see if the coax cable is damaged or crimped. Difficulty adjusting the antenna can also be caused by a tilted antenna, interference from nearby metal object, or an improperly grounded system. You may also try moving the antenna to a different location on your vehicle.

EXTERNAL SPEAKER

This radio is equipped with a jack for an external speaker. This jack is in the rear of the radio and is labeled "EXT. SP.". Only use a speaker that can handle 4 watts, 8 ohms of impedance. The internal speaker will not work if an external speaker is connected to the radio.

PUBLIC ADDRESS

To use the Public Address (PA) function, first connect an external speaker to the PA. SP. jack on the rear of the radio. See the above specifications for a proper external speaker. Keep the speaker away from the microphone to avoid feedback.

- 6 -

CHAPTER 4 INSTALLATION

FRONT PANEL

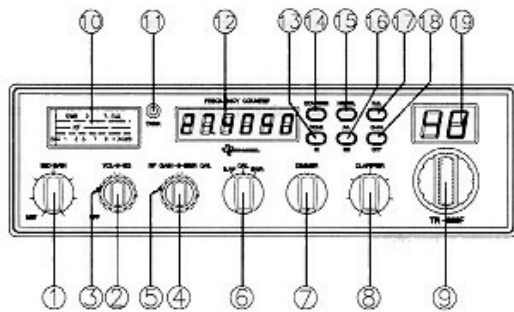

1. **MIC GAIN/ANF** : This is a multi function switch which controls both the gain to the microphone as well as the ANF (Advanced Noise Filter). In the outer position, the switch controls the ANF which improves the signal to noise ratio when receiving a marginal signal. When the switch is in the inner position it controls the amount of gain to the microphone.
2. **ON/OFF VOLUME CONTROL** : This knob controls the volume and the power to the radio. To turn the radio on, rotate the knob clockwise. Turning the knob further will increase the volume of the receiver.
3. **SQUELCH CONTROL** : This switch is used to eliminate background noise being heard through the receiver which can be disturbing when no transmissions are being received. To use this feature of your radio, gently turn the switch counterclockwise until the switch will not turn further. Then turn the switch clockwise until the background noise is just eliminated. If you turn the switch too far in a clockwise direction, you may not be able to hear weak transmissions.

- 7 -

4. **RF GAIN CONTROL** : A strong signal can overpower the RF amplifier. This control is used to reduce the gain from strong signals.
5. **SWR CAL CONTROL** : This control allows the user to calibrate the SWR meter, which is used to match the antenna to your radio.
6. **S-RF/CAL/SWR SWITCH** : This is a three function switch. In the S-RF position, the meter will indicate the strength of the signal being received, as well as the relative RF output of transmission. When calibrating the SWR meter, you need to put this switch in the CAL position. To use the meter to measure the standing wave ratio, turn the switch to the SWR position.
7. **DIMMER CONTROL** : This knob controls the level of brightness for the meter lamp, the frequency display and the channel display.
8. **CLARIFIER** : Allows tuning of the received frequency above or below the channel frequency by up to 1.5 KHz .
9. **CHANNEL SELECTOR** : This control is used to select a desired transmit and receive channel.
10. **FRONT PANEL METER** : The Front Panel Meter allows the user to monitor signal strength, RF output power and SWR level.
11. **TX/RX LED** : The red LED indicates the unit is in the transmit mode. The green LED indicates the unit is in the receive mode.
12. **FREQUENCY COUNTER** : This display indicates the frequency of the selected channel .
13. **TONE/HI SWITCH** : This switch changes the tone quality. Press this switch (TONE) and bass is increased . Depress this switch (HI) and treble is increased.
14. **COUNTER SWITCH** : Press this switch for the frequency of the selected channel to be displayed on the frequency counter.

- 8 -

15.NB/ANL/OFF SWITCH : In the NB/ANL position, the RF Noise Blanker and the Automatic Noise Limiter in the audio circuits are also activated. The Noise Blanker is very effective in eliminating repetitive impulse noise such as ignition interference.

16.CB/PA SWITCH : This switch allows you to operate the radio in either the CB or as a PA system. In the PA mode, the radio will not transmit or receive CB signals. It will broadcast through the external speaker plugged into the PA. SP. jack in the rear of the radio. Note: Make sure the speaker is plugged into the jack labeled PA. SP. and NOT the jack labeled EXT. SP.

17.R.B. : In the Roger Beep position, the radio transmits an audio tone at the end of your transmission. This indicates the end of your transmission so that people who are having trouble hearing you will know that you are done speaking. As a courtesy to others, use the Roger Beep only when necessary.

18. CH 19 SWITCH : The channel 19 switch is used for instant access to Channel 19, which is often used by truckers for transmission of traffic and weather condition.

19.CHANNEL DISPLAY : The channel display indicates the current selected channel.

REAR PANEL

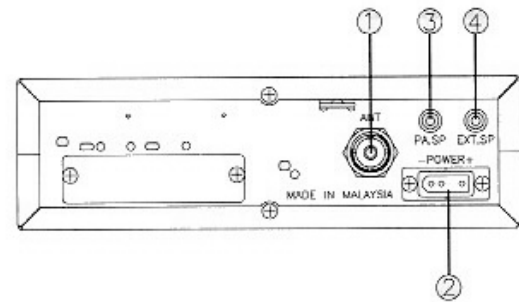

1. **ANTENNA :** This jack accepts 50 ohms coaxial cable with a PL-259 type plug.

2. **POWER :** This accepts 13.8V DC power cable with built-in fuse. The power cord provided with the radio has a black and red wire. The black goes to negative and the red goes to positive.

3. **PA. SP. :** This jack is for PA operation. Before operating, you must first connect a PA speaker (8 ohms, 4W) to this jack.

4. **EXT. SP. :** This jack accepts 4 to 8 ohms, 5 watts external speaker. When the external speaker is connected to this jack, the built-in speaker will be disabled.

PROCEDURE TO RECEIVE AND TRANSMIT

A. PROCEDURE TO RECEIVE

1. Before turning on the radio, make sure the radio is properly installed in your vehicle and that the microphone and antenna have been connected. Make sure your antenna has been properly matched to your radio.
2. Turn unit on by turning the ON/OFF VOL knob clockwise .
3. Make sure your radio is set to CB and not PA.
4. Adjust the squelch so that any background noise is eliminated. See prior section of this manual for information on how to properly adjust the squelch.
5. Turn the channel selector to the channel you wish to monitor.
6. Turn the RF gain control fully clockwise initially, and then adjust when a signal is received.

B. PROCEDURE TO TRANSMIT

1. Before turning on the radio, make sure the radio is properly installed in your vehicle and that the microphone and antenna have been connected. Make sure your antenna has been properly matched to your radio.
2. Turn unit on by turning the ON/OFF VOL knob clockwise.
3. Make sure your radio is set to CB and not PA.
4. Set the MIC GAIN control to maximum gain.
5. To transmit over your radio, hold the microphone approximately two inches from your mouth. Depress the push-to-talk switch on the microphone and talk in a clear voice. When you release the push-to-talk switch, the radio will be in the receive mode.

MICROPHONE INSTALLATION AND SUBSTITUTES

This radio is designed for use with, and supplied with, a low impedance dynamic microphone. If you replace the microphone supplied with this radio, you should use either a low-impedance microphone, or a transistorized one.

Replacement microphones must have a four-lead cable to properly work with this radio. The microphone should be wired in accordance with the microphone wiring table and schematic below.

4 WIRE MIC CABLE

Pin Number	Mic. Cable Lead
1	Audio Shield
2	Audio Lead
3	Transmit Control
4	Receive Control

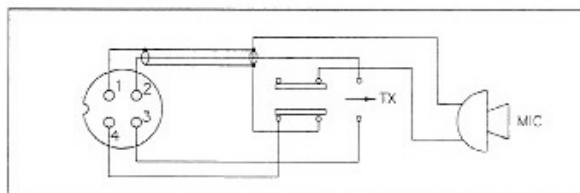

Fig. 1 Schematic of microphone

If the new microphone you are using has pre-cut leads, you must re-connect the leads in the following manner :

1. Cut leads so that they extend 7/16" beyond the insulating jacket of the cable. All leads should be approximately the same length.
2. Strip approximately 1/8" of the insulation. Tin all leads and connections before soldering.

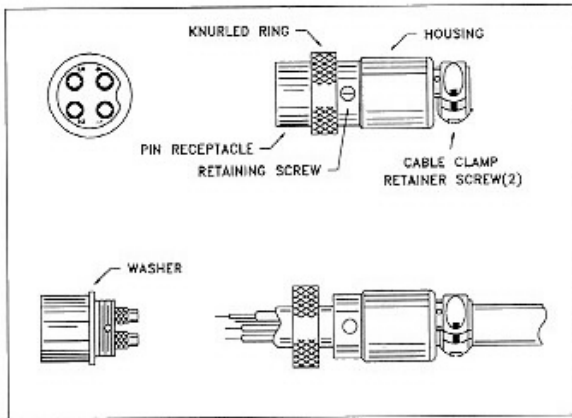

Fig. 2 Microphone plug wiring

Referring to Fig. 2 above,

3. Remove the retaining screw.
4. Unscrew the housing .
5. Loosen cable clamp screws.
6. Thread cable through the housing, knurled ring and washer.
7. Solder the wires to the pins in accordance with the microphone wiring table above and figure 3 below. Before soldering, the washer must be placed on the threaded portion of the pin receptacle body.

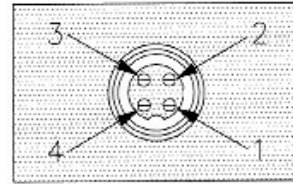

Fig 3. Microphone pin numbers

8. Once all soldering is complete, you may re-assemble the unit. When assembling, make sure that the wires do not touch each other or any other metal parts. Check for excessive solder which could cause a short. To re-assemble, screw the housing onto the pin receptacle body. Make sure the screw hole and threaded hole line up, and then replace the retaining screws.

Your microphone should now be ready to use with your radio.

